

MINI ONE

MEMS AVCS GYRO

www.cnchelicopter.com



Preface

The MINI ONE is an extremely high quality precision controller of a model helicopter flight control gyro. It provides greatly consistent yaw rates that avoid outside variables like the helicopter's rotor head speed, rotor disc loading, flight speed, wind, etc. with the aids of a premium quality sensor and a powerful controller. This significant feature is a necessity for doing complex pirouetting 3D manoeuvres. The MINI ONE will enable you to enjoy a high performance by its excellent location capability and precision.

The MINI ONE offers two operating modes: Normal mode and AVCS mode.

Specefication and spare parts

Sensor Type: MEMS

Operating voltage: 4-10 Volts, current < 60mA

Operating conditions: -10°C to +50°C

Overall dimensions: 20.5mm×19.5mm×10mm

Weight: 10 grams

Servo compatibility: 1520us-333Hz, 1520us-250Hz, 760us-500Hz, 960us-333Hz digital servos and 1520us-71Hz analog servos.

Spare parts: foam and double-side adhesive tape, stainless steel plate.

Installation

When mounting the MINI ONE, ensure that The bottom plane of the gyro is perpendicular to the main shaft of the helicopter using double-side adhesive tape in the mounting kit.

Please only use a double side adhesive pad, when installing the MINI ONE to an electric helicopter. If installing on a nitro or turbine helicopter, you may want to use a double sided adhesive pad on the bottom, plus a stainless plate on the top, then plus a double sided adhesive pad on the top layer for better vibration isolation.

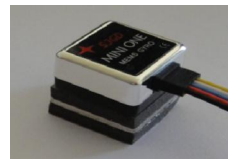

Interconnections

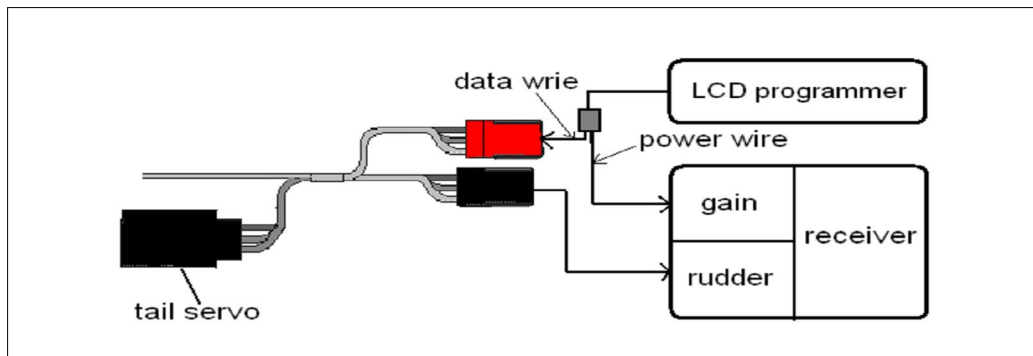
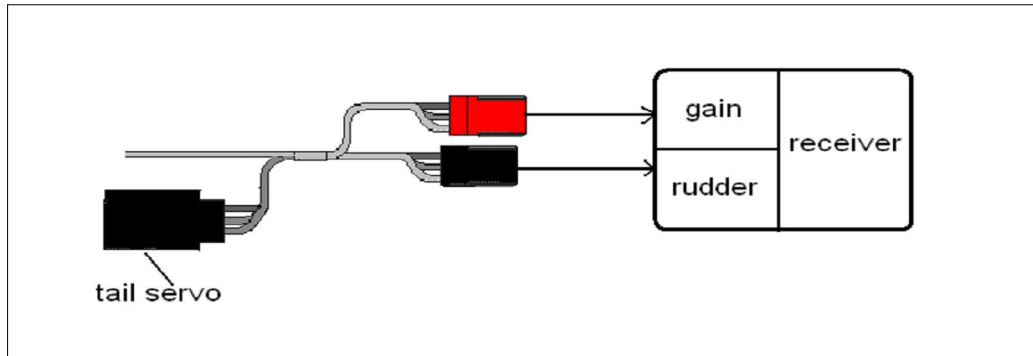

Note: When LCD program connect the gain plug of MINI ONE, the LED is off on MINI ONE. MINI ONE is normal mode.

The connecting line from LCD program must connect to the GAIN of MINI ONE firstly, then to power, and last to LCD program.

Operating instructions

It is necessary for you to follow these following steps in specified order to successfully install your new MINI ONE.

- | Connect MINI ONE to the receiver. Do not connect the servo to the MINI ONE at this time.
- | Assign gyro gain to a 2 position switch to facilitate switching between Normal and AVCS.
- | Ensure that the transmitter trims and sub-trims are set to zero and that collective pitch to tail pitch mixing is disabled. Power on the MINI ONE and check that the LED responds when toggling the gain switch. When the LED is on it is AVCS mode and off for Normal mode.
- | Refer to the following LCD Setting Adaptor guide for detailed setting.
- | Connect the servo to the MINI ONE.
- | In Normal mode perform mechanical adjustment of the servo horn and control linkages to achieve approximately 8deg tail pitch.
- | Adjust gyro gain for both Normal and AVCS modes via your transmitter.
- | Perform final checks. Confirm correct relationship of rudder stick and gyro response to tail movement. Confirm that there is no mechanical binding.

Note: Before the MINI ONE power up, the gain value is too low in transmitter, the MINI ONE will enter the protection state, the tail servo does not work.

Setting

LCD Configuration Steps :

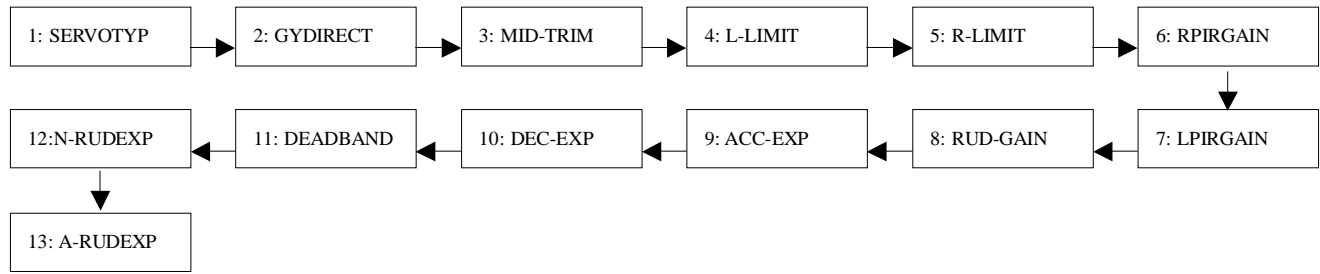

Power On : Once power on, LCD will display HELLO. After 5 seconds, configuration card will display gyro settings and is ready for use.

Default Setting : When HELLO is display, press + 10 and - 1 buttons simultaneously. Configuration will return to default value.

System Reset : Reset button is located at the bottom of LCD configuration card.

Button Description :

Total 7 function keys: FUNC+, FUNC-, +10, -10, +1, -1, Reset

Description	Function
FUNC+, FUNC-	Scroll up/down function menu
+10, -10	Increase (+) or decrease (-) value by 10 units each time. Automatically change to 1 units if the maximum function value is less than 20.
+1, -1	Increase (+) or decrease (-) value by 1 unit each time.
Reset	System reset

Detailed settings of Function Menu:

1、SERVOTYP servo type selection	
Menu Items	Description
152-33 (Default)	Servo pulse width 1520us, working frequency 333Hz includes : Futaba : S9253、S9254、S9650、S9257、S3153、BLS254 JR : 8900G、DS3400、DS3500 Hitec : HS-5083MG、HS-5925MG、6965HB LogicTech : 3100G Most digital servo without special marking should be in this category.
76-50	Servo pulse width 760us, working frequency 500Hz includes : Futaba : S9251、S9256、BLS251 MKS: DS8910、BLS980
152-25	Servo pulse width 1520us, working frequency 250Hz includes : Futaba : S3154 JR : 8700G、2700G、810G

	Align : DS510、DS520、DS620 Sky: HDS-577、HDS-877
96-33	Servo pulse width 960us, working frequency 333Hz includes : LogicTech : 6100G、3100G Hitec: 5083MG
152-07	Servo pulse width 1520us, working frequency 71Hz includes : analog servo, low-speed digital servo.

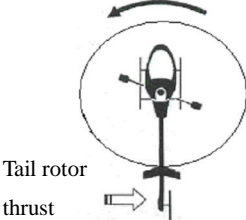
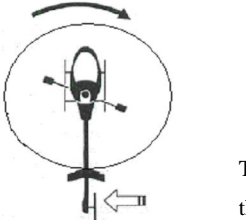
2、GYDIRECT Gyro direction selection	
Attention: Check that the rudder direction matches the transmitter stick direction. Otherwise, please reverse the rubber servo direction in transmitter program.	
<div style="display: flex; justify-content: space-around;"> <div style="text-align: center;"> <p>Direction of resulting yaw.</p>  <p>Tail rotor thrust →</p> </div> <div style="text-align: center;"> <p>Direction of resulting yaw</p>  <p>Tail rotor thrust ←</p> </div> </div>	
Menu items	Description
NORM (Default)	Rotate the helicopter left (nose). Rudder servo should compensate to the right automatically. Otherwise, change value to "REV". As shown in the diagram
REV	Rotate the helicopter left (nose). Rudder servo should compensate to the right automatically. Otherwise, change value to "NORM". As shown in the diagram.

3、MID-TRIM Rudder Servo Neutral Adjustment	
Attention: Rudder SUB TRIM value of Transmitter should be set to zero . Install rudder servo horn to closest to 90 degree. Use MID-TRIM to fine tune the neutral point of servo horn to achieve exact 90 degree. Check the neutral position by switching the MINI ONE to the NOR mode, or by moving the rudder stick to the left and right at least three times at high speed and immediately returning the stick to the neutral position. This temporarily resets the rudder servo.	
Menu items	Description
-100 ~ 0 ~ +100 (Default 0)	Fine tune rudder servo neutral point.

4、L-LIMIT Rudder Left Pitch Travel Limit	
Menu items	Description
0 ~ 240 (Default 160)	Adjust rudder servo travel at end limit.
Suggestion	Suggested setting between 160 ~ 230. If setting is higher than 230, please install ball link to the outer hole of servo horn or use longer horns. If setting is lower than

	160, please install ball link to the inner hole of servo horn or use shorter horns. It is recommended to keep difference between L-LIMIT and R-LIMIT within ± 20 .
--	--

5、 R-LIMIT Rudder Right Pitch Travel Limit	
Menu items	Description
0 ~ 240 (Default 160)	Adjust rudder servo travel at end limit.
Suggestion	Suggested setting between 160 ~ 230. If setting is higher than 230, please install ball link to the outer hole of servo horn or use longer horns. If setting is lower than 160, please install ball link to the inner hole of servo horn or use shorter horns. It is recommended to keep difference between R-LIMIT and L-LIMIT within ± 20 .

6、 RPIRGAIN Right Piro Stop Gain	
Menu items	Description
50 ~ 200 (Default 100)	The higher the setting, the harder the braking effect in piro stops. The lower the setting, the softer the braking effect in piro stops.
Suggestion	If tail bounce back occurs, please lower the setting . Excess hard braking for piro stop will affect the service life of rudder servo!

7、 LPIRGAIN Left Piro Stop Gain	
Menu items	Description
50 ~ 200 (Default 100)	The higher the setting, the harder the braking effect in piro stop . The lower the setting, the softer the braking effect in piro stop .
Suggestion	If tail bounce back occurs, please lower the setting . Excess hard braking for piro stop will affect the service life of rudder servo!

8、 RUD-GAIN Rudder Stick Gain	
Menu items	Description
50 ~ 150 (Default 100)	Fine tune the stick response to the actual piro rate. The higher the setting, the more sensitive the stick movement.

9、 ACC-EXP Acceleration Curve	
Menu items	Description
0 ~ 15 (Default 0)	The higher the value, the smoother and longer it takes to reach piro speed from static.

10、 DEC-EXP Deceleration Curve	
Menu items	Description
0 ~ 15 (Default 0)	The higher the value, the longer it takes for the tail to slow down. Used to smoothen the deceleration of piro when coming to a stop.

11、DEADBAND	
Menu items	Description
5 ~ 100 (Default 5)	Rudder has no response if stick movement in deadband zone. Useful to prevent minor unintentional rudder stick commands.

12、N-RUDEXP Normal Rudder Curve	
Menu items	Description
-100 ~ +100 (Default 0)	Normal Gyro expo curve to the stick movement in non-head lock mode

13、A-RUDEXP AVCS Rudder Curve	
Menu items	Description
-100 ~ +100 (Default 0)	AVCS Gyro expo curve to the stick movement in head lock mode

Gyro activation auto-check

When you power on the MINI ONE, it will immediately perform automatic calibration of the rudder stick and gyro natural points. During this time the helicopter must remain undisturbed and the rudder stick must be left at the neutral point. The calibration lasts approximately 3 seconds and upon completion the tail servo will move to the middle. The calibration will not start if the MINI ONE is not receiving a valid rudder signal from the receiver or if the rudder stick is not centred. In both cases the LED will emit the Error flashing sequence (see Status LED section later in this instruction).

Status LED

During normal operation the LED provides simple status information for users.

On :	AVCS mode. Stick at neutral.
Short blink three times:	AVCS mode. Rudder input detected.
Off :	Normal mode.
repeating flash:	Error. Gyro not receiving valid signal from the receiver or unable to calibrate because the rudder stick is not centred.

Double check your work after all settings are made!

Warm tips: Please take care of FS600 ! Do not open the bottom cover of FS600 housing to avoid damaging product.

For updates to the instruction manual, please visit our web site www.sjgd-tech.com